

TU series

Undermount units TU 900, TU 1100,
TU 1250, TU 1250 Multi-Temp



The benefits of the MITSUBISHI undermount units are recognised worldwide. Underfloor mounting allows a higher cab or lower body because there is no need to install a condenser on the bulkhead.

The TU 1250 Multi-Temp undermount unit allows you to choose between two or three lanes or compartments.

Locating the condenser under the box provides better weight distribution and a reduced front axle loading. In addition, less operating noise is transmitted to the cab.

A user-friendly in-cab remote control means the operator can operate and monitor the system from the safety of the cab via a digital display.

The unit chassis and trim are specially designed for undermount applications being both robust and proven against corrosion protection. The start/ stop system

combines with the unique and efficient 3D scroll compressor with output control to reduce fuel consumption and give measurable cost savings.

Unit components are carefully designed and rigorously tested by MITSUBISHI to guarantee a dependable, efficient and high-performing refrigeration system.

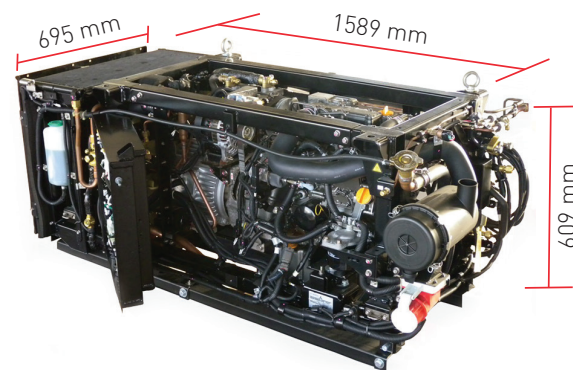

MOVE THE WORLD FORWARD

MITSUBISHI
HEAVY
INDUSTRIES
GROUP



Remote control

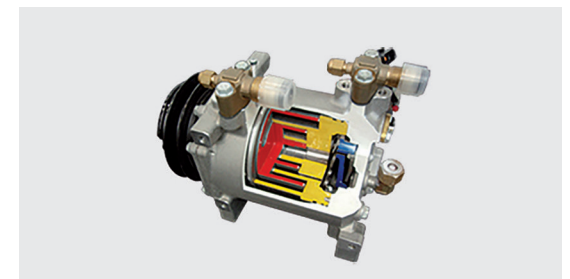

3D scroll compressor

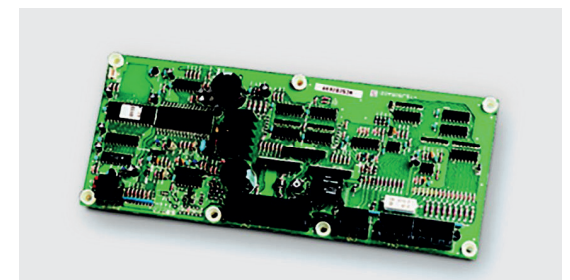

Microprocessor

MITSUBISHI

Transport Refrigeration



Benefits:

- > High cooling capacity protects the most sensitive cargoes
- > Compact dimensions suit small trucks
- > 3D scroll compressor for high cooling capacity at low engine speeds
- > Electronic fuel pump
- > Long maintenance intervals for low maintenance costs
- > Exceptional MITSUBISHI reliability
- > Control of the individual temperatures of all compartments by electronic injection valves
- > Low emissions to protect the environment
- > Low operating noise (65-69 dB(A)) ideal for urban distribution
- > Start/Stop system saves fuel
- > Clean air routing for unrestricted air circulation and accurate temperature control
- > User-friendly In-cab remote control with LCD-display and USB-port, multi-lingual
- > Timer function
- > Evaporator option for transport with tube tracks

**MITSUBISHI HEAVY INDUSTRIES
THERMAL TRANSPORT EUROPE**

Hannoversche Straße 49
49084 Osnabrück - Germany

Tel.: +49 (0)541 80005-0
Fax: +49 (0)541 80005-250

Internet: www.mhi-tte.com
Email: info@mhi-tte.com

	TU 900 SAE Slim evaporator	TU 1100 SAE Slim evaporator	TU 1250 SAE Slim evaporator	TU 1250 SAE Multi Slim evaporator
Cooling capacity (ATP tested)				
to 0 °C	9683 watt	10421 watt	11601 watt	max. 12127 watt
to -20 °C	5478 watt	5647 watt	6741 watt	max. 6588 watt
Refrigerant	R452A	R452A	R452A	R452A
Evaporator size	1450 x 743 x 200 mm	2000 x 743 x 200 mm	2000 x 743 x 200 mm	depending on system configuration
Air flow	1974 m³/h	2663 m³/h	2663 m³/h	depending on system configuration
Weight	475 kg	490 kg	490 kg	Condenser: 435 kg Evaporator L : 50 kg Evaporator MW : 37 kg Evaporator M : 31 kg Evaporator S : 25 kg
Engine	Yanmar 3TNV76 / 3 cylinder / 1116 cm³ / 12.5 KW	Yanmar 3TNV76 / 3 cylinder / 1116 cm³ / 12.5 KW	Yanmar 3TNV76 / 3 cylinder / 1116 cm³ / 12.5 KW	Yanmar 3TNV76 / 3 cylinder / 1116 cm³ / 12.5 KW

This Product contains fluorinated greenhouse gases (R452A / GWP = 2,139).



Low maintenance

- > Major components requiring maintenance are easily accessible and have long service intervals.



Evaporator

- > Low-maintenance evaporator fans



Compressor

- > 3D scroll compressor



Electric motor

- > Powerful Fuji electric motor, with automatic phase detection



Microprocessor

- > Controls all system functions.
- > Alarms are indicated by codes displayed on the remote control.



Standard

- > Automatic diesel start-up in the event of a power failure.



Hot water heating coil optional available

- > For even more heating capacity

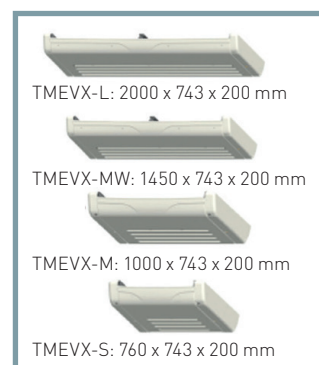

Evaporator

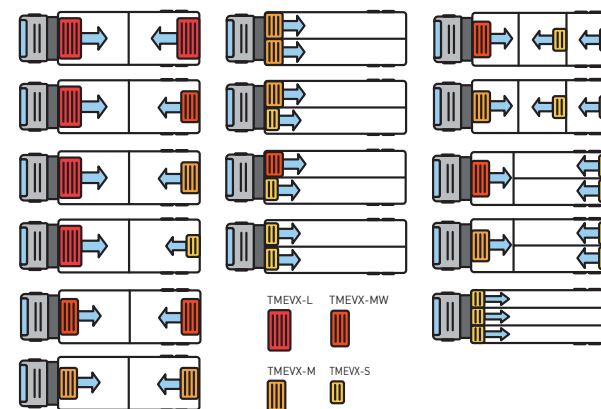

MOVE THE WORLD FORWARD

**MITSUBISHI
HEAVY
INDUSTRIES
GROUP**